

INNALABS[®]

Coriolis Vibratory Gyros

CVG-25

Datasheet

November, 2009

This document contains information proprietary to Innalabs

The solid state **Innalabs® CVG-25 Gyro** with metal cylindrical resonator is designed to measure angular rate. They are ideal for applications that demand high operation accuracy, low cost, and good shock and vibration resistance. It has price-to-performance ratio better than FOGs. Design of gyroscope sensing element is patents pending.

FEATURES

- High-performance bias stability
- Low noise
- Light weight
- Long life and high reliability
- Excellent vibration performance
- Free for export
- Low price

APPLICATIONS

- Land vehicle control
- Remotely operated vehicles
- Avionics systems
- Borehole surveying
- Missiles and rockets
- Naval equipment
- Platform stabilization
- Robots

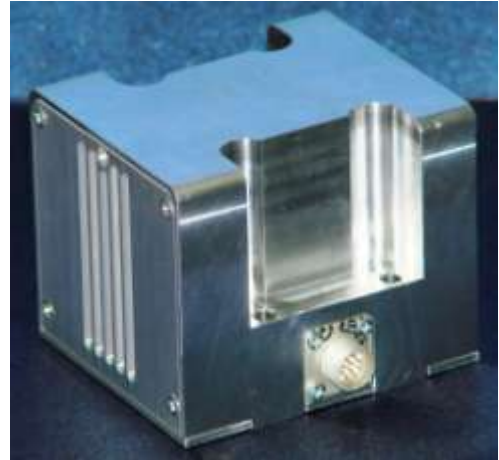

The Innalabs® Coriolis Vibratory Gyroscope (CVG) is the world's first low-cost, high-performance gyroscope utilizing the superior technology provided by Coriolis Vibratory techniques. Our patented design delivers high performance and low cost in a small form-factor. With no moving parts, the CVG is designed for outstanding performance under harsh environmental conditions, and is ideally suited for a wide range of commercial, aerospace and military applications.

The Innalabs® CVG25 output interface is RS-485. The CVG gyro output signal is digital one and comes to user in the digital form as a number of counts averaged over sample time. This number of counts should be divided by scale factor to obtain average value of angle rate in deg/s. The minimum sampling step is 5 msec or on demand.

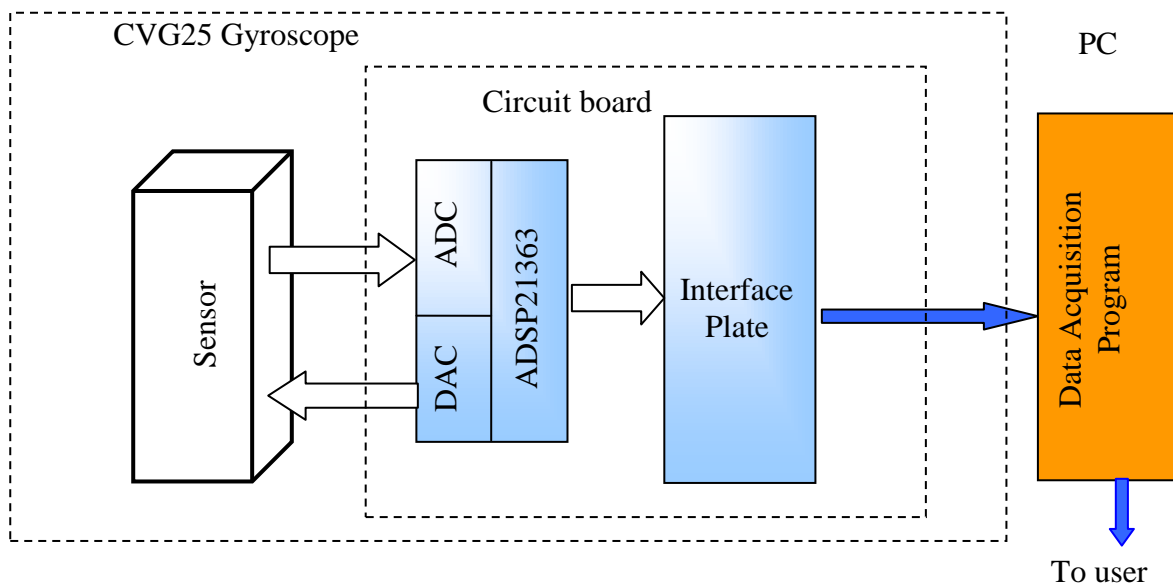

SPECIFICATIONS

Parameter	Unit	Gyro Category		
		L1	L2	L3
Input angular rate	deg/s	± 150...200		
Bandwidth	Hz	50...100		
Normal Environmental Condition (25 deg C)				
Scale factor linearity ($\sigma(SF)/SF$)	%	0.02...0.05	0.05...0.1	< 0.1
SF Repeatability turn-on to turn-on	%	0.02...0.05	0.05...0.1	< 0.1
Short term SF Stability (1 σ , 1 day)	%	0.01...0.03	0.03...0.1	< 0.1
Long term SF Stability (1 σ , day-to-day)	%	0.1...0.2	0.2...0.5	< 1
Bias stability (Allan Variance)	deg/hr	0.5...1	1...3	3...5
Short-term bias stability (1 σ , 100-sec averaging time)	deg/hr	0.5...1	1...5	5...15
Long-term bias stability (1 σ , 1-hour averaging time)	deg/hr	0.3...1	1...5	5...15
Random Walk	deg/ \sqrt{h}	0.03...0.05	0.05...0.1	< 0.3
Temperature Range -40 to +50 deg C (temperature ramp rate is $\leq 1^\circ$ C/min)				
Bias stability (Allan variance)	deg/hr	<3	3...5	< 10
Short-term bias stability (1 σ , 100-sec averaging time)	deg/hr	1...5	5...15	< 30
Long-term bias stability (1 σ , 1-hour averaging time)	deg/hr	1...5	5...15	< 30
Short-term bias stability (1 σ , 100-sec averaging time) at any constant temperature within the range	deg/hr	1...3	3..5	< 30
Long-term bias stability (1 σ , 1-hour averaging time) at any constant temperature within the range	deg/hr	1...3	3...5	< 30
Random Walk	deg/ \sqrt{h}	0.05...0.1	0.1...0.2	< 0.5
Scale Factor Temperature Sensitivity	%/ deg C	0.0015...0.002	0.002...0.005	< 0.015
Environmental				
Operating temperature	deg C	-40 to + 50		
Storage temperature	deg C	-40 to + 75		
Shock survival		1000 g (estimated value)		
Vibration survival		20 g RMS, 20...2000Hz		
Physical				
Supply voltage	+ V	15...30		
Power consumption	watts	< 3		
Interface		RS-485		
Output data		Average angular rate and temperature (4-byte float numbers) in a data sampling step		
Data output mode		<ul style="list-style-type: none"> • Continuous data output over an asynchronous interface at 600 Hz with no sync-in and sync-out signals • Data sampling time synchronization via acceptance of sync-in commands from an external controller at 0.5-200 Hz 		
Dimension 1 axis	mm	72 W x 60 H x 62 L		
Weight	g	400		

OUTLINE DRAWING

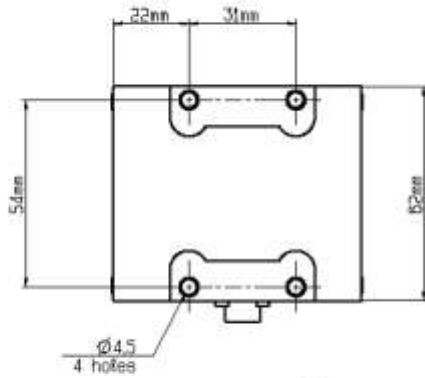
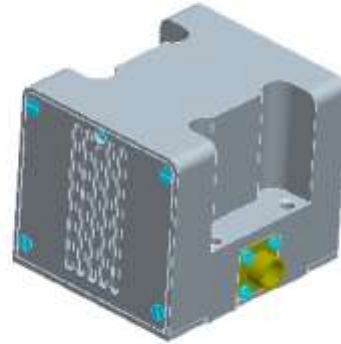
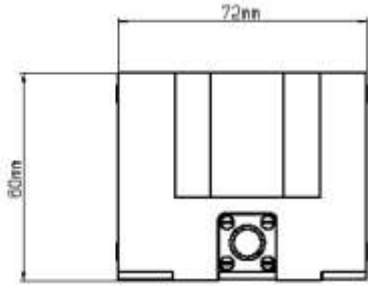

Plug

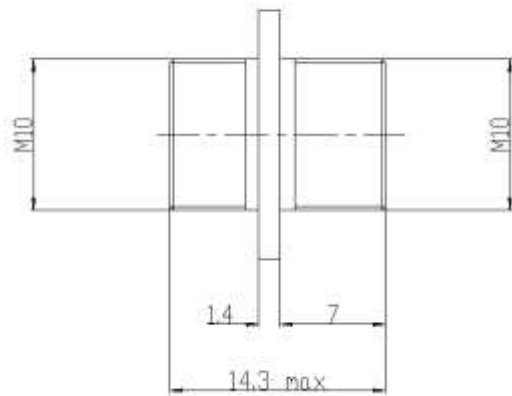
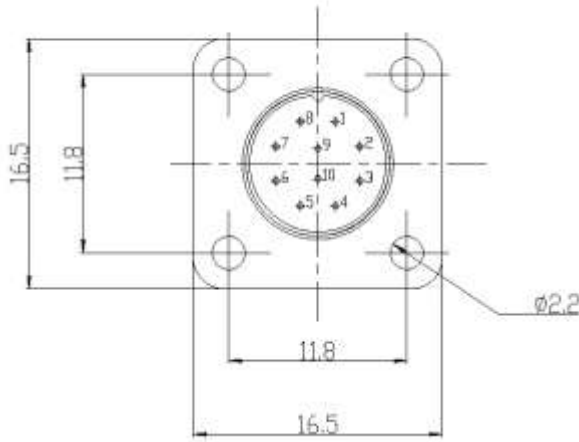

Cable receptable

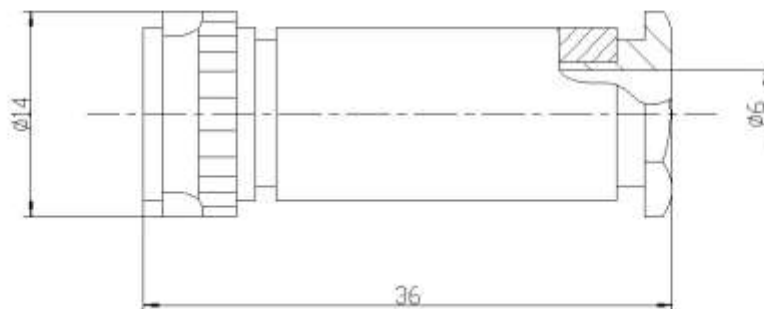

Voltage supply to Innalabs® CVG25 and information output are provided through single output connector MP-1-10 located on the CVG. The figure depicts the connector pin assignments.

MP1-10-1-B	
Pin	Circuit
1	RS485A
2	NC
3	+ (15..30) V
4	+ (15..30) V
5	0 V
6	0 V
7	NC
8	RS485 B
9	NC
10	Gnd

