

# **Innalabs<sup>®</sup>**

## **Micromachined Gyroscope**

### **Three-axis**

# **INN-107**

## **Datasheet**

**November, 2009**

This document contains information proprietary to Innalabs<sup>®</sup>

The **Innalabs**<sup>®</sup> **INN-107** **Micromachined Gyroscope** is a solid-state three-axis angular rate sensor that outputs a DC voltage proportional to the rate of turn and input voltage. It utilizes a micromachined, vibrating quartz technology where the Coriolis Effect is used to measure angular rotation rate. The use of piezoelectric quartz material ensures exceptional stability over temperature and long product life.

### Features

- Rate-grade three-axis gyroscope
- Compact Design & Low Cost
- Different Accuracy Modifications Available
- Wide Measurement Range, up to  $\pm 3000$  deg/sec
- Fast Start-Up
- Internal Power Regulation
- Wide Bandwidth

### Applications

- Antenna & Platform Stabilization
- Navigation Systems
- Instrumentation
- Robotics & Vehicles
- Precision Farming
- Factory Automation
- Medical/Orthopedic



The **Innalabs**<sup>®</sup> **INN-107** sets a new standard for performance and price. High reliability, low cost and compact design make this sensor the best choice for low-cost inertial measurement units (IMU), inertial navigation systems (INS), and attitude & heading reference systems (AHRS).

**Innalabs Holding Inc.**

Address: 10 Pidgeon Hill Dr, Suite 80, Sterling, VA 20165, USA  
Tel: +1 (703) 596-0276, +1 (703) 880-4222, Fax: +1 (703) 935-8377  
E-mail: [contact.sales@innalabs.com](mailto:contact.sales@innalabs.com)  
Website: [www.innalabs.com](http://www.innalabs.com)

## SPECIFICATIONS

#	Parameter	Unit	INN-107-3	INN-107-2	INN-107-1
<b>1.</b>	<b>Performance</b>				
1.1	Measurement Range	deg/sec	±100 ... ±3000	±50 ... ±500	±50 ... ±200
1.2	Full Scale Output	V	0 - 5 or ±5		
1.3	Bias Calibration	V	2.5±0.05 or 0±0.05		
1.4	Bias Stability at const. temperature, 10 sec averaging time	deg/sec	0.05	0.03	0.01
1.5	Angle Random Walk	deg/√h	1 ... 1.5		
1.6	Scale Factor nonlinearity	%FS	0.08	0.05	0.05
1.7	Sensitivity	deg/sec	0.02	0.015	0.01
1.8	G Sensitivity	deg/sec/g	0.05	0.05	0.05
<b>2.</b>	<b>Dynamic Characteristic</b>				
2.1	Start up time	sec	1		
2.2	Bandwidth	Hz	60		
<b>3.</b>	<b>Environment</b>				
3.1	Operating temperature	degC	-40 ... +70		
3.2	Storage temperature	°C	-55 ... +85		
3.3	Vibration	g, RMS	2 , 20 Hz to 2 kHz random		
3.4	Shock	g	500 g, 5 ms		
<b>4.</b>	<b>Electrical</b>				
4.1	Data interface		Analog		
4.2	Input Voltages	V	+8 ... +12 or ±8 ... ±12		
4.3	Input Current	mA	30 or 60		
<b>5.</b>	<b>Physical</b>				
5.1	Dimensions (L*W*H)	mm	50 * 40 * 30		
5.2	Weight	grams	120		

**Dimensions drawing (mm):**

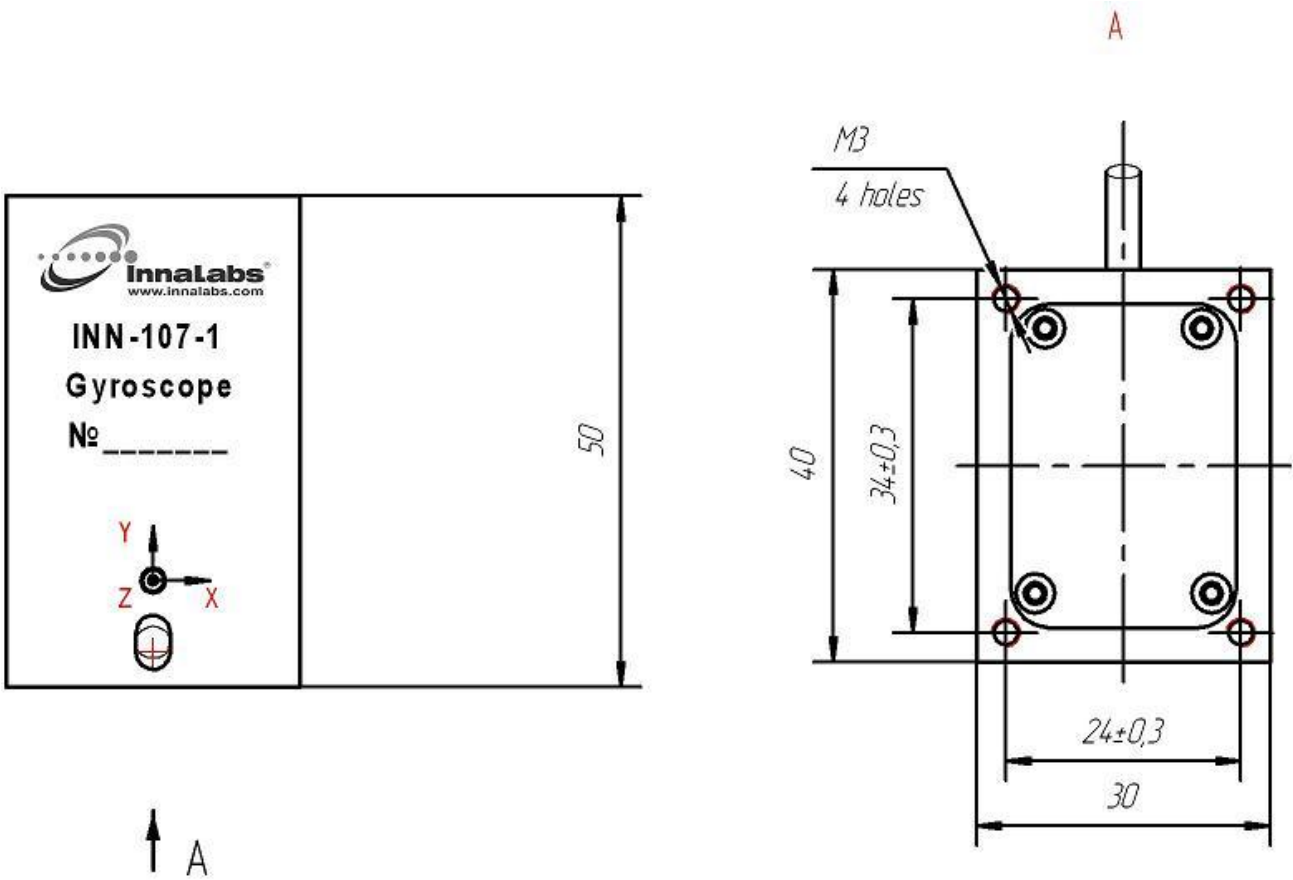

**For more information please contact us:**

**Innalabs Holding Inc.**

Address: 10 Pidgeon Hill Dr, Suite 80, Sterling, VA 20165, USA  
 Tel: +1 (703) 596-0276, +1 (703) 880-4222, Fax: +1 (703) 935-8377  
 E-mail: [contact.sales@innalabs.com](mailto:contact.sales@innalabs.com)  
 Website: [www.innalabs.com](http://www.innalabs.com)

**Innalabs Holding Inc.**

Address: 10 Pidgeon Hill Dr, Suite 80, Sterling, VA 20165, USA  
 Tel: +1 (703) 596-0276, +1 (703) 880-4222, Fax: +1 (703) 935-8377  
 E-mail: [contact.sales@innalabs.com](mailto:contact.sales@innalabs.com)  
 Website: [www.innalabs.com](http://www.innalabs.com)